

12V DC Peristaltic Dosing Pump

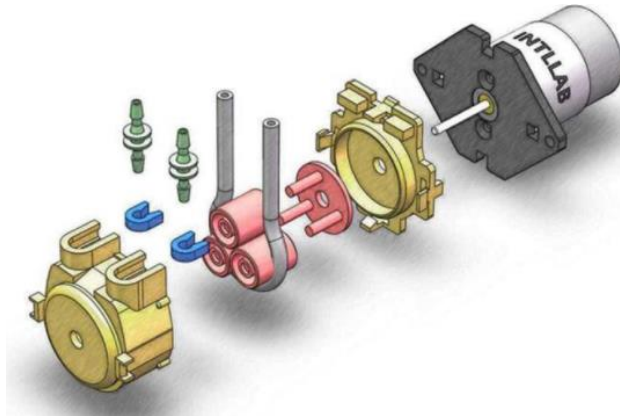

Features:

- POWERFUL - Suitable for viscous, non-viscous liquid
- EASY USE - The pump head designed for easy disassembly, easy to clean and maintain.
- CHANGEABLE FLOW DIRECTION - flow direction can be controlled by the positive and negative connection.



- PORTABLE FOR WIDE USE - has been widely used in the field of experimental, biochemical analysis, pharmaceuticals, fine chemicals, biotechnology, pharmaceutical products, ceramics, water treatment, environmental protection, etc.

Dimension:

